

CEE 3804 Assignment 10 Solution

Problem 1

Task 1

The Simulink model to solve the non-linear ODE is shown below.

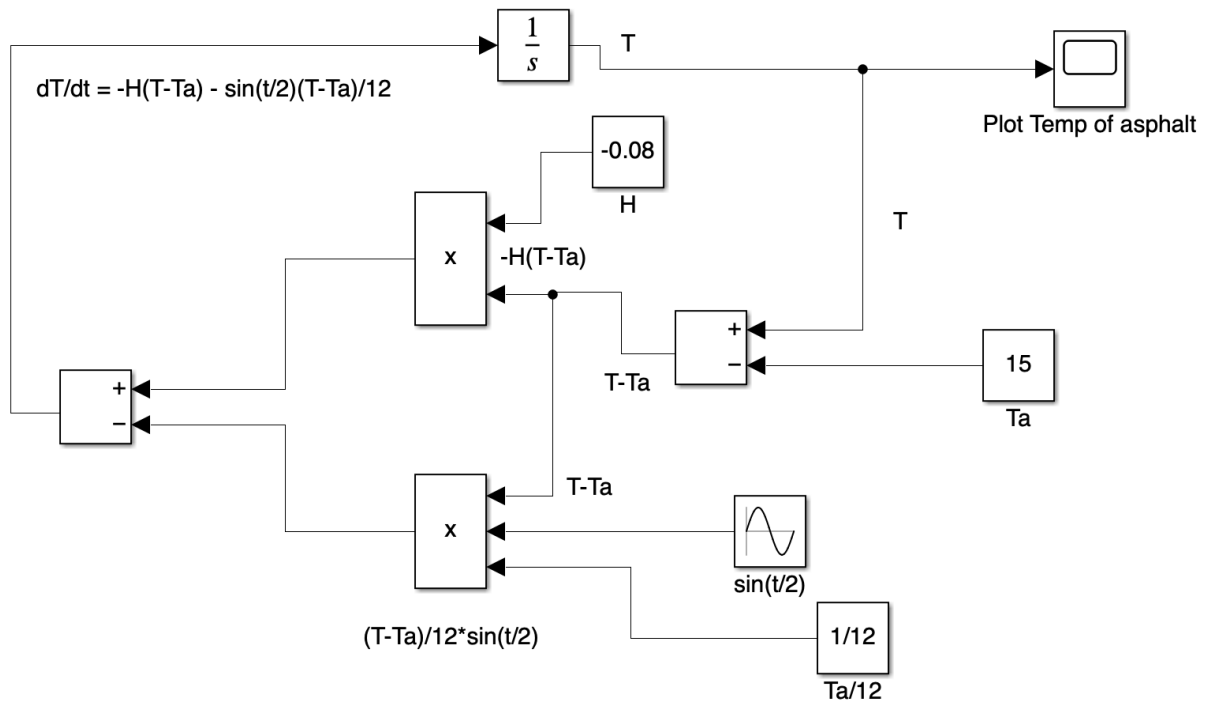

The sine wave block is used to generate the term: $\sin(t/2)$. Frequency 0.2 is equivalent to $t/2$.

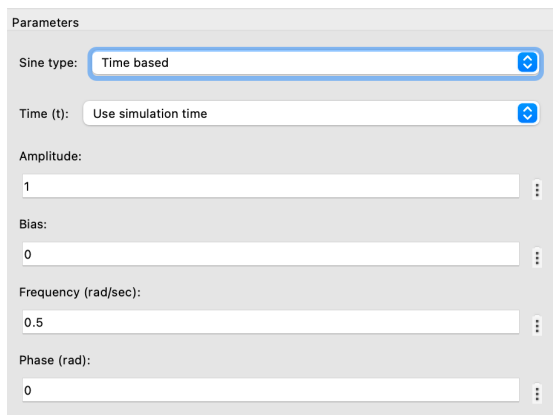

Task 2

Use initial conditions and parameters: $T_a=15$ (C), $H=0.08$ (1/minute), $T_0=150$ (C)

Task 3

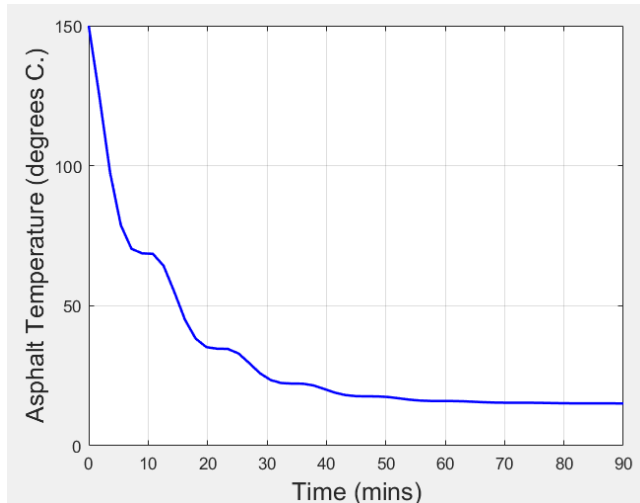

```
%% Problem 1 Task 3
Time_mins=out.ScopeData(:,1);
Temp_asphalt_degree_C=out.ScopeData(:,2);
h1=plot(Time_mins,Temp_asphalt_degree_C);
grid on
h1.Color='b';
h1.LineWidth=1.5;
xlabel('Time (mins)',FontSize=15)
ylabel('Asphalt Temperature (degrees C.)',FontSize=15)
```

Task 4

The first time within 3% is 68.4 minutes.

```
%% %% Problem 1 Task 4
idx=find(Temp_asphalt_degree_C<=15*1.03);|
the_first_time_within_3percent=Time_mins(idx(1));
disp(['The first time within 3% is ',num2str(the_first_time_within_3percent),' minutes.'])
```

Problem 2

Task 1

Method 1 (learned in class)

Function (below) to estimate the rate of change of temperature (T) with time (t).

```
% First Order Differential Equation Function

% where:
% H is a cooling constant (1/time)
% T is the temperature of the element of interest (deg C)
% Ta is the ambient temperature (deg C)

function [tprime] = ftem(t,T)

global Ta H

% tprime = - H * (T - Ta);
tprime = - H * (T - Ta) - sin(t/2)*(T-Ta)/12;
tprime = tprime';
```

Matlab script (below) to call the function above and solve the problem using ODE45 solver.

```
% Solution to First-Order Equation of the form:
%
% dT/dt = - H * (T - Ta)
%
% subject to initial conditions:
%
% T (t=0) = To
%
% where:
% H is a cooling constant (1/time)
% T is the temperature of the element of interest (deg C)
% Ta is the ambient temperature (deg C)

global Ta H

% Define Initial Conditions of the Problem

To = 150; % To is the initial temperature of the fin
to = 0.0; % to is the initial time to solve this equation (min)
tf = 90; % tf is the final time (min)

% define T ambient (Ta) and cooling constant (H)

Ta = 15;
H = 0.08;
tspan = [to tf];

[t, T] = ode45('ftem', tspan, To);
```

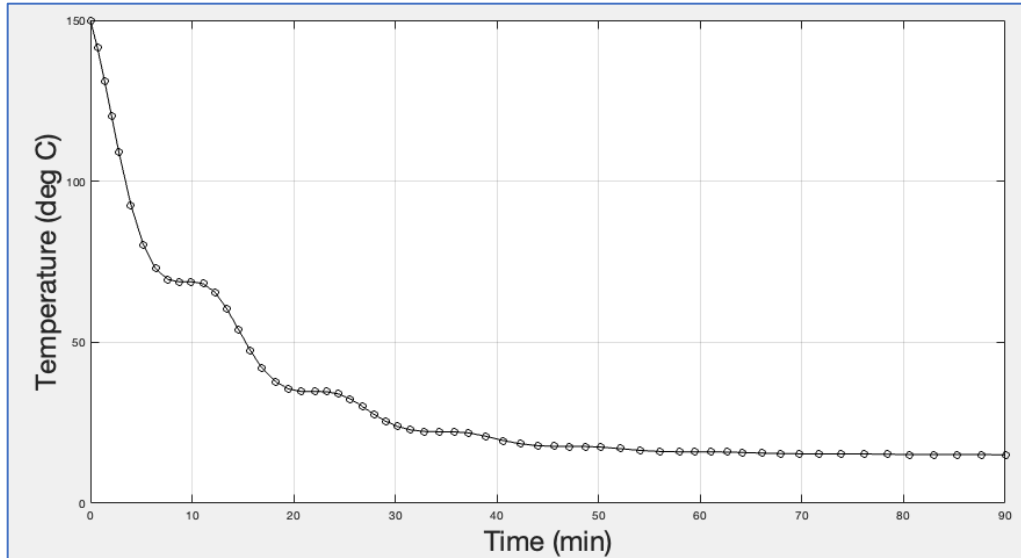

Temperature profile using ODE45.

Method 2 with embedded function into Matlab script

```
function dydt = myode(t,y,ft,f,gt,g)
f = interp1(ft,f,t); % Interpolate the data set (ft,f) at time t
g = interp1(gt,g,t); % Interpolate the data set (gt,g) at time t
dydt = -f.*y + g; % Evaluate ODE at time t
end

%% Problem 2 Task 1
ft = linspace(0,90,901);
f = 0.08+sin(ft*0.5)*1/12;

gt = linspace(0,90,901);
g = 15*0.08+sin(gt*0.5)*15/12;

tspan = [0 90];
ic = 150;
%opts = odeset('RelTol',1e-2,'AbsTol',1e-4);
[Time_mins_p2,Temp_asphalt_degree_C_p2] = ode45(@(t,y) myode(t,y,ft,f,gt,g), tspan, ic);
```

Task 2

According to the following two lines, we can find that the solution is the same.

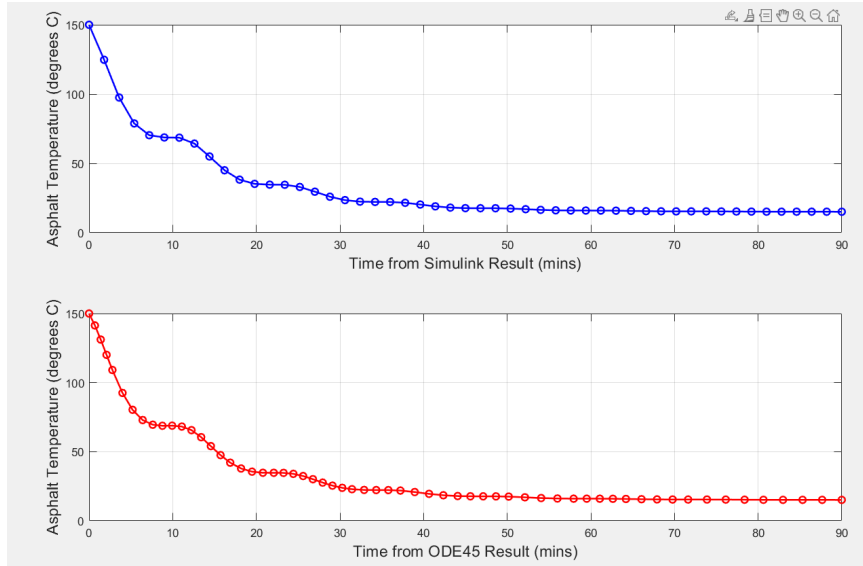

%% Problem 2 Task 2

```

subplot(2,1,1)
h1=plot(Time_mins,Temp_asphalt_degree_C);
grid on
h1.Color='b';
h1.LineWidth=1.5;
h1.Marker='o';
xlabel('Time from Simulink Result (mins)',FontSize=14)
ylabel('Asphalt Temperature (degrees C)',FontSize=14)
subplot(2,1,2)
h2=plot(Time_mins_p2,Temp_asphalt_degree_C_p2);
grid on
h2.Color='r';
h2.LineWidth=1.5;
h2.Marker='o';
xlabel('Time from ODE45 Result (mins)',FontSize=14)
ylabel('Asphalt Temperature (degrees C)',FontSize=14)

```